



DOUBLE-WALL DRAWER SYSTEMS

MAGIC-STAR PLUS

MAGIC-STAR PLUS

The Metal Straight-sided Slim Drawer

A Perfect Mix of Function and Elegance



- Linear slim drawer sides - a fashion look and elegant appearance
- Perfect connection between components makes a beautiful drawer



Quietness



Intelligence



Durability



Eco-Friendliness

MAGIC-STAR PLUS

HD11 Series Straight-sided Drawer System (Low Drawer: M Height)

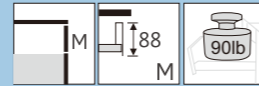

PRODUCT

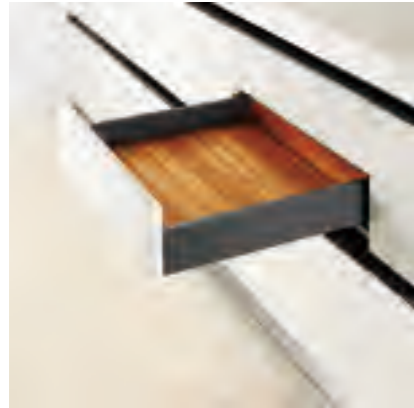

DESCRIPTION

- Concealed, full extension
- Load capacity: 90lb(40kg)
- Tool free assembly and removal of drawer
- Silent system guarantees smooth run without noise
- 3D adjustment:
 - Up & down adjustment: ±2mm
 - left & right adjustment: ±1.2mm
 - tilt adjustment: +0.5mm, -2.5mm
- Finish: Silk white(E29), Grey matt(E30)

SPACE REQUIREMENT

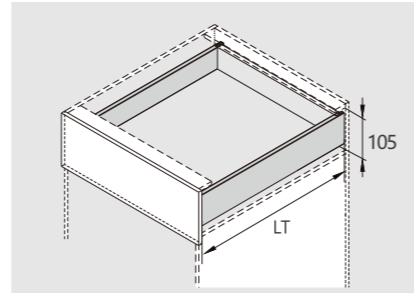

LT=Internal Cabinet Depth
LT=NL+3

PLANNING

Installation Dimensions(mm)

NL=Nominal Slide Length
LT=Internal Cabinet Depth
LT=NL+3

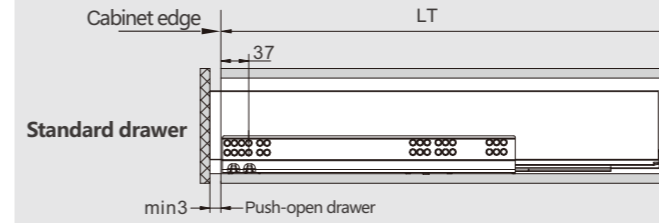

Cabinet Configuration

Cabinet widths/KB(mm)	Push-open drawer Synchronization rod	
300	○	○ recommended
350	○	
400	○	
450	○	
500	○	
600	○	
800	●	● strongly recommended
900	●	
1000	●	
1200	●	

LOW DRAWER FOR WOOD DRAWER BACK

Kit Package			
Silk White(E29)! Grey Matt(E30)!			
NL	Soft Close item No.	Push-open item No.	Set/ctn
270mm	HD11270A17X	HD41270A17X	1
300mm	HD11300A17X	HD41300A17X	1
350mm	HD11350A17X	HD41350A17X	1
400mm	HD11400A17X	HD41400A17X	1
450mm	HD11450A17X	HD41450A17X	1
500mm	HD11500A17X	HD41500A17X	1
550mm	HD11550A17X	HD41550A17X	1
600mm	HD11600A17X	HD41600A17X	1

1 Slides (left/right) /Industrial Package			
Pre-zinc Steel(F02)			
NL	Soft Close item No.	Push-open item No.	Set/ctn
270mm	HD10270H	HD40270H	5
300mm	HD10300H	HD40300H	5
350mm	HD10350H	HD40350H	5
400mm	HD10400H	HD40400H	5
450mm	HD10450H	HD40450H	5
500mm	HD10500H	HD40500H	5
550mm	HD10550H	HD40550H	5
600mm	HD10600H	HD40600H	5

2 Drawer Sides and Cover Caps (left/right) /Industrial Package			
Silk White(E29)! Grey Matt(E30)!			
NL	Item No.	Set/ctn	
270mm	HE112707X	5	
300mm	HE113007X	5	
350mm	HE113507X	5	
400mm	HE114007X	5	
450mm	HE114507X	5	
500mm	HE115007X	5	
550mm	HE115507X	5	
600mm	HE116007X	5	

3 Front Fixing-brackets (left/right) / Industrial Package			
Pre-zinc Steel(F02)			
	Item No.	Set/ctn	
Screw-on	HE11011X	120	
Press-in	HE11016X	120	

30 Rod for Push-open Synchronization / Industrial Package			
Size:1100mm.Cutting:Internal cabinet width LW-172 for Nominal Side Length: 350mm、400mm、450mm、500mm、550mm、600mm			
Item No.	HT0FH02	Set/ctn	60

4 Fixing-brackets			
Zinc plated(B04)			
Item No.	HT10082	Pcs/ctn	400

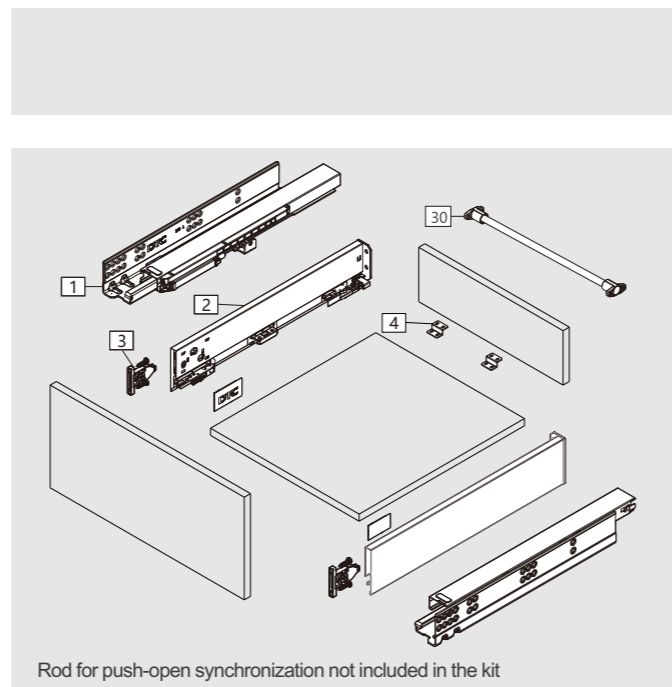

Screw Positions of the Slides(mm)

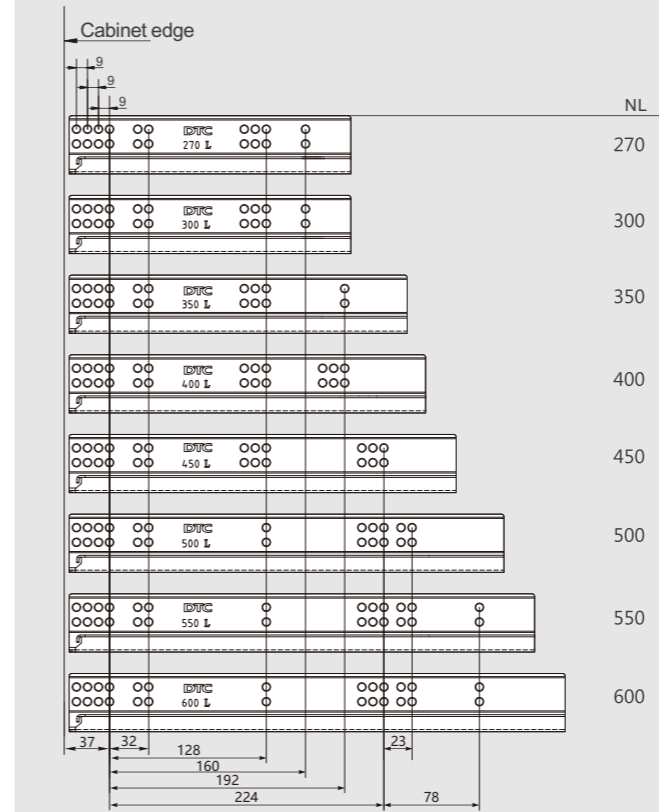

Installation Dimensions(mm)

LW=Internal Cabinet Width

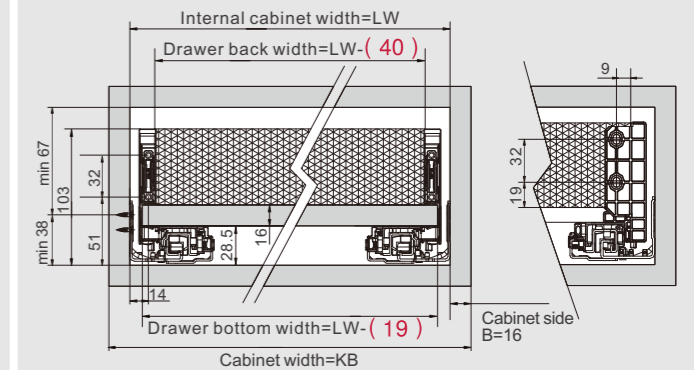

Drawer Front, Back and Bottom Dimensions(mm)

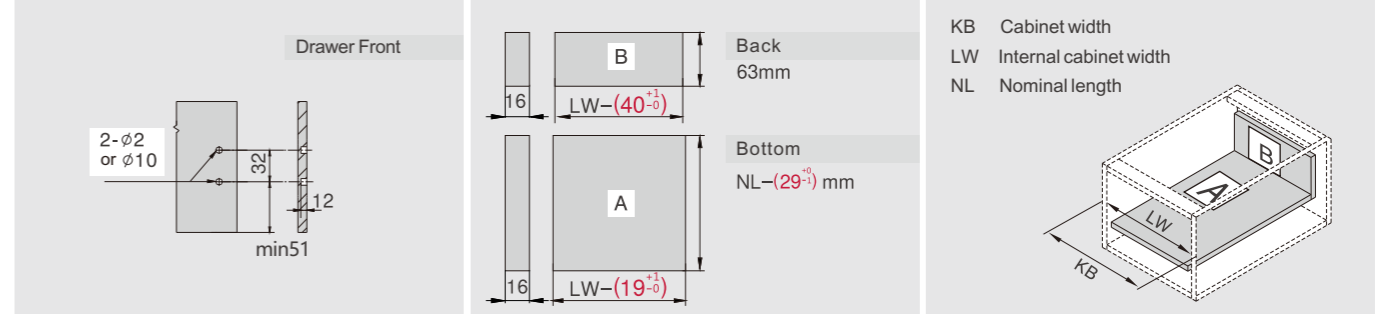

MAGIC-STAR PLUS

HD11 Series Straight-sided Drawer System (Low Inner Drawer: M Height)

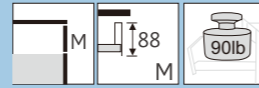

PRODUCT



DESCRIPTION

- Concealed, full extension
- Load capacity: 90lb(40kg)
- Tool free assembly and removal of drawer
- Silent system guarantees smooth run without noise
- 3D adjustment:
 - Up & down adjustment: $\pm 2\text{mm}$
 - left & right adjustment: $\pm 1.2\text{mm}$
 - tilt adjustment: $+0.5\text{mm}, -2.5\text{mm}$
- Finish: Silk white(E29), Grey matt(E30)

SPACE REQUIREMENT

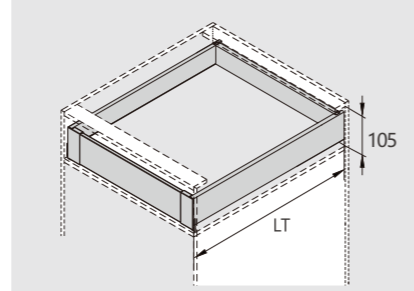

LT=Internal Cabinet Depth
Soft close slides LT=NL+3
Push-open slides LT=NL+13

PLANNING

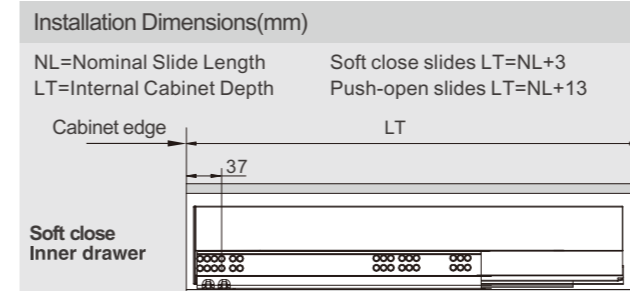

Cabinet widths/KB(mm)	Push-open drawer Synchronization rod	
300	○	○ recommended
350	○	
400	○	
450	○	
500	○	
600	○	● strongly recommended
800	●	
900	●	
1000	●	
1200	●	

LOW INNER DRAWER FOR WOOD DRAWER BACK

Kit Package				1 Slides (left/right) /Industrial Package				2 Drawer Sides and Cover Caps (left/right) /Industrial Package			
Silk White(E29)! Grey Matt(E30)!				Pre-zinc Steel(F02)				Silk White(E29)! Grey Matt(E30)!			
NL	Soft Close item No.	Push-open item No.	Set/ctn	NL	Soft Close item No.	Push-open item No.	Set/ctn	NL	Item No.	Set/ctn	
270mm	HD11270Q17X	HD41270Q17X	1	270mm	HD10270H	HD40270H	5	270mm	HE112707X	5	
300mm	HD11300Q17X	HD41300Q17X	1	300mm	HD10300H	HD40300H	5	300mm	HE113007X	5	
350mm	HD11350Q17X	HD41350Q17X	1	350mm	HD10350H	HD40350H	5	350mm	HE113507X	5	
400mm	HD11400Q17X	HD41400Q17X	1	400mm	HD10400H	HD40400H	5	400mm	HE114007X	5	
450mm	HD11450Q17X	HD41450Q17X	1	450mm	HD10450H	HD40450H	5	450mm	HE114507X	5	
500mm	HD11500Q17X	HD41500Q17X	1	500mm	HD10500H	HD40500H	5	500mm	HE115007X	5	
550mm	HD11550Q17X	HD41550Q17X	1	550mm	HD10550H	HD40550H	5	550mm	HE115507X	5	
600mm	HD11600Q17X	HD41600Q17X	1	600mm	HD10600H	HD40600H	5	600mm	HE116007X	5	

3	Front Fixing-brackets (left/right) / Industrial Package White(H03)! Dark Grey(H11)	Item No. HD11012X	Set/ctn 60
---	---	--------------------------	------------

5	Front Section / Industrial Package Size:1100mm.Cutting:Internal cabinet width LW-97	Item No. HT10022	Set/ctn 20
---	--	-------------------------	------------

30	Rod for Push-open Synchronization / Industrial Package Size:1100mm.Cutting:Internal cabinet width LW-172 for Nominal Side Length: 350mm, 400mm, 450mm, 500mm, 550mm, 600mm	Item No. HT0FH02	Set/ctn 60
----	---	-------------------------	------------

4	Fixing-brackets Zinc plated(B04)	Item No. HT10082	Pcs/ctn 400
---	-------------------------------------	-------------------------	-------------

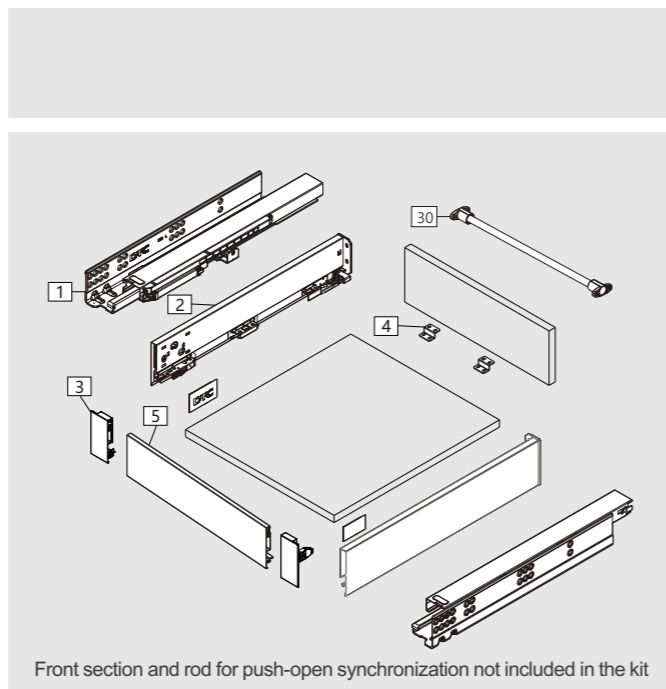

Fixing Hole Position for Push-open Inner Drawer(mm)

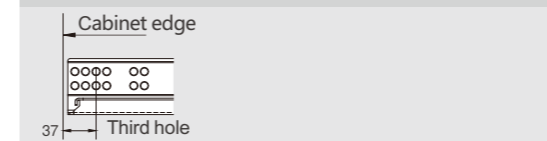

Screw Positions of the Slides(mm)

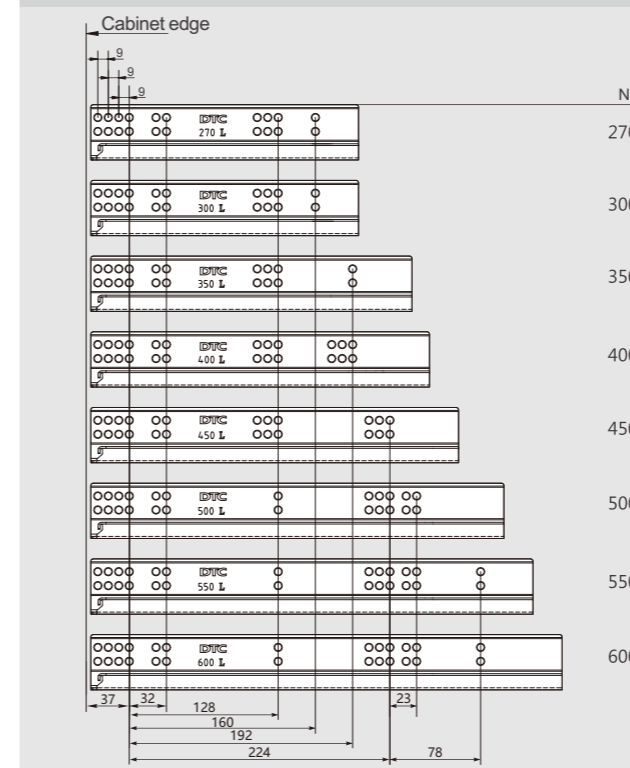

Installation Dimensions(mm)

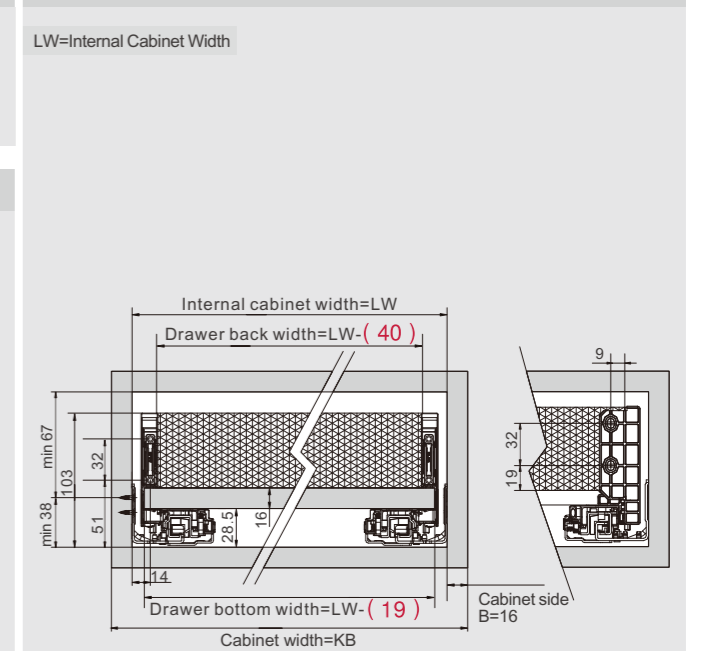

Front Section, Back and Bottom Dimensions(mm)

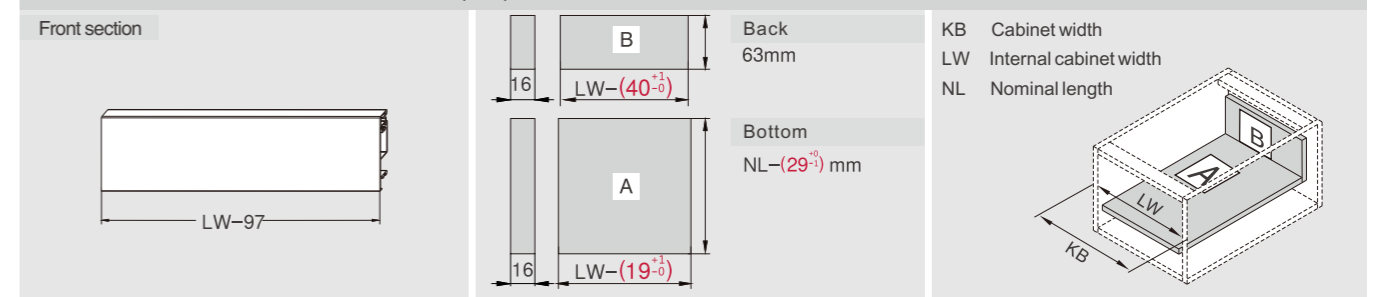

MAGIC-STAR PLUS

HD12 Series Straight-sided Drawer System (Medium Drawer: K Height)

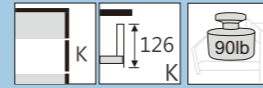

PRODUCT



DESCRIPTION

- Concealed, full extension
- Load capacity: 90lb(40kg)
- Tool free assembly and removal of drawer
- Silent system guarantees smooth run without noise
- 3D adjustment:
 - Up & down adjustment: ±2mm
 - left & right adjustment: ±1.2mm
 - tilt adjustment: +0.5mm, -2.5mm
- Finish: Silk white(E29), Grey matt(E30)

SPACE REQUIREMENT

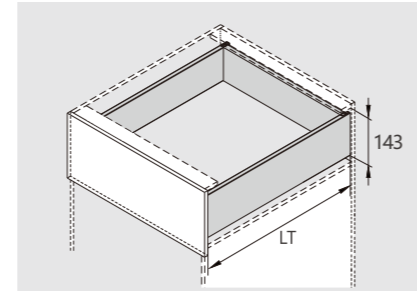

LT=Internal Cabinet Depth
LT=NL+3

PLANNING

Installation Dimensions(mm)

NL=Nominal Slide Length
LT=Internal Cabinet Depth
LT=NL+3

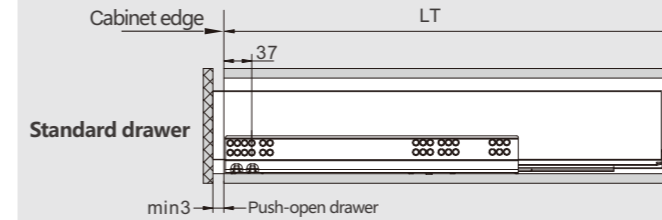

Cabinet Configuration

Cabinet widths/KB(mm)	Push-open drawer Synchronization rod	
300	○	○ recommended
350	○	
400	○	
450	○	
500	○	
600	○	● strongly recommended
800	●	
900	●	
1000	●	
1200	●	

MEDIUM DRAWER FOR WOOD DRAWER BACK

Kit Package			
Silk White(E29)! Grey Matt(E30)!			
NL	Soft Close item No.	Push-open item No.	Set/ctn
270mm	HD12270A17X	HD42270A17X	1
300mm	HD12300A17X	HD42300A17X	1
350mm	HD12350A17X	HD42350A17X	1
400mm	HD12400A17X	HD42400A17X	1
450mm	HD12450A17X	HD42450A17X	1
500mm	HD12500A17X	HD42500A17X	1
550mm	HD12550A17X	HD42550A17X	1
600mm	HD12600A17X	HD42600A17X	1

1 Slides (left/right) /Industrial Package			
Pre-zinc Steel(F02)			
NL	Soft Close item No.	Push-open item No.	Set/ctn
270mm	HD10270H	HD40270H	5
300mm	HD10300H	HD40300H	5
350mm	HD10350H	HD40350H	5
400mm	HD10400H	HD40400H	5
450mm	HD10450H	HD40450H	5
500mm	HD10500H	HD40500H	5
550mm	HD10550H	HD40550H	5
600mm	HD10600H	HD40600H	5

2 Drawer Sides and Cover Caps (left/right) /Industrial Package			
Silk White(E29)! Grey Matt(E30)!			
NL	Item No.	Set/ctn	
270mm	HE122707X	5	
300mm	HE123007X	5	
350mm	HE123507X	5	
400mm	HE124007X	5	
450mm	HE124507X	5	
500mm	HE125007X	5	
550mm	HE125507X	5	
600mm	HE126007X	5	

3 Front Fixing-brackets (left/right) / Industrial Package			
Pre-zinc Steel(F02)			
	Item No.	Set/ctn	
Screw-on	HE12011X	120	
Press-in	HE12016X	120	

30 Rod for Push-open Synchronization / Industrial Package			
Size:1100mm.Cutting:Internal cabinet width LW-172 for Nominal Side Length: 350mm、400mm、450mm、500mm、550mm、600mm			
Item No.	HT0FH02		
Set/ctn	60		

4 Fixing-brackets			
Zinc plated(B04)			
Item No.	HT10082		
Pcs/ctn	400		

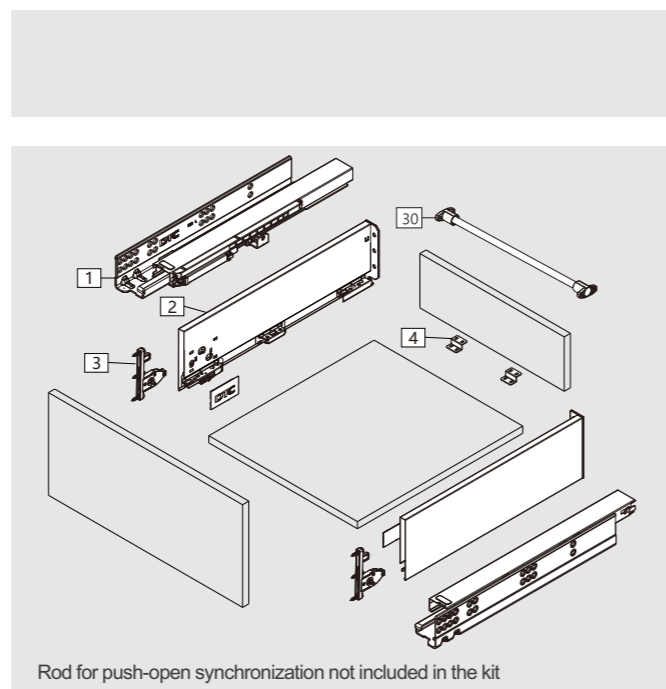

Screw Positions of the Slides(mm)

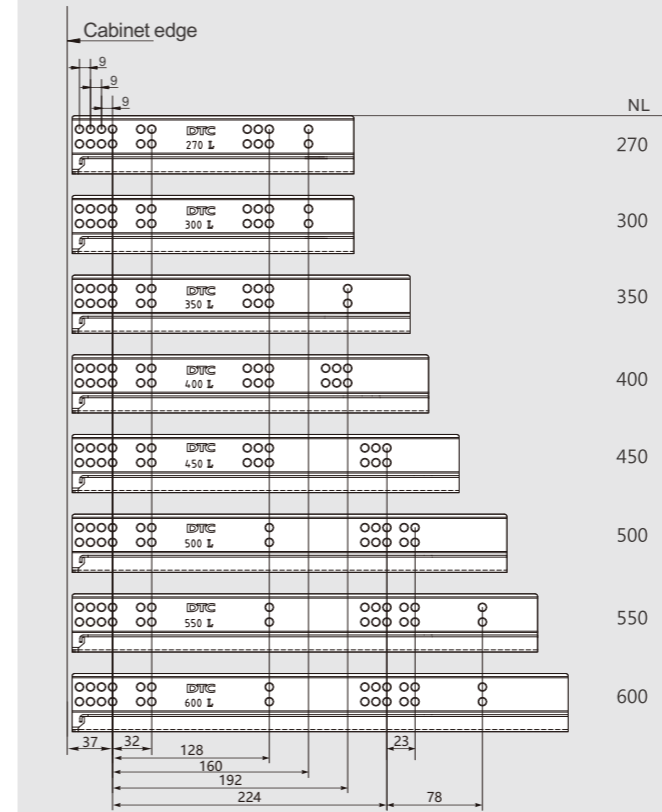

Installation Dimensions(mm)

LW=Internal Cabinet Width

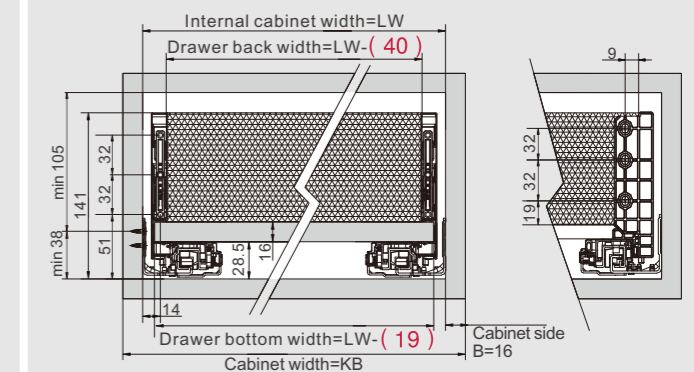

Drawer Front, Back and Bottom Dimensions(mm)

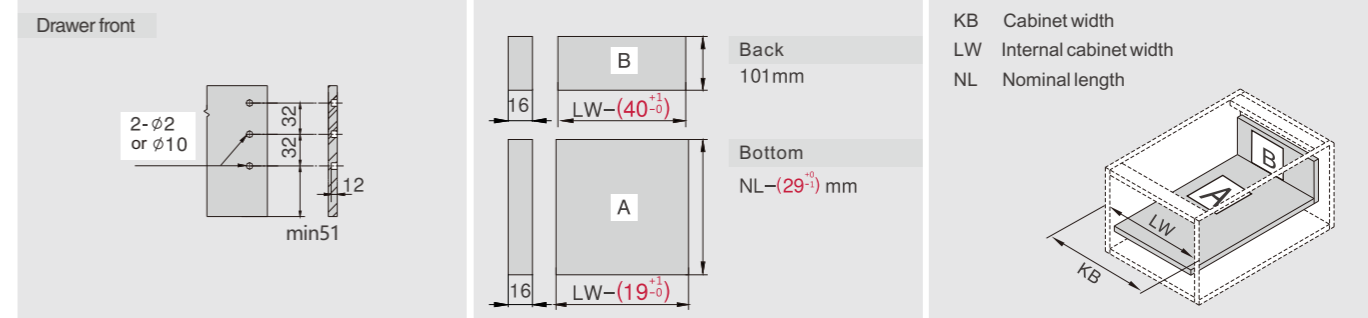

MAGIC-STAR PLUS

HD13 Series Straight-sided Drawer System (High Drawer: C Height)

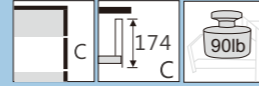

PRODUCT



DESCRIPTION

- Concealed, full extension
- Load capacity: 90lb(40kg)
- Tool free assembly and removal of drawer
- Silent system guarantees smooth run without noise
- 3D adjustment:
Up & down adjustment: ±2mm
left & right adjustment: ±1.2mm
tilt adjustment: +0.5mm, -2.5mm
- Finish: Silk white(E29), Grey matt(E30)

SPACE REQUIREMENT

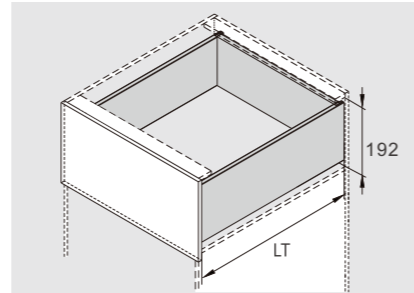

LT=Internal Cabinet Depth
LT=NL+3

PLANNING

Installation Dimensions(mm)

NL=Nominal Slide Length
LT=Internal Cabinet Depth
LT=NL+3

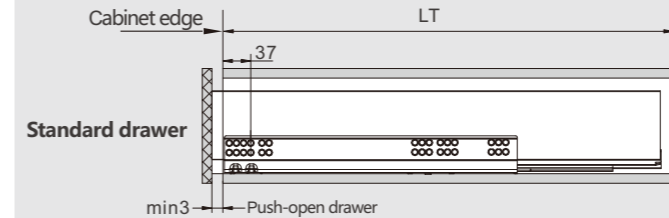

Cabinet Configuration

Cabinet widths/KB(mm)	Push-open drawer Synchronization rod	
300	○	○ recommended
350	○	
400	○	
450	○	
500	○	
600	○	● strongly recommended
800	●	
900	●	
1000	●	
1200	●	

HIGH DRAWER FOR WOOD DRAWER BACK

Kit Package			
Silk White(E29)! Grey Matt(E30)!			
NL	Soft Close item No.	Push-open item No.	Set/ctn
270mm	HD13270A17X	HD43270A17X	1
300mm	HD13300A17X	HD43300A17X	1
350mm	HD13350A17X	HD43350A17X	1
400mm	HD13400A17X	HD43400A17X	1
450mm	HD13450A17X	HD43450A17X	1
500mm	HD13500A17X	HD43500A17X	1
550mm	HD13550A17X	HD43550A17X	1
600mm	HD13600A17X	HD43600A17X	1

1 Slides (left/right) /Industrial Package			
Pre-zinc Steel(F02)			
NL	Soft Close item No.	Push-open item No.	Set/ctn
270mm	HD10270H	HD40270H	5
300mm	HD10300H	HD40300H	5
350mm	HD10350H	HD40350H	5
400mm	HD10400H	HD40400H	5
450mm	HD10450H	HD40450H	5
500mm	HD10500H	HD40500H	5
550mm	HD10550H	HD40550H	5
600mm	HD10600H	HD40600H	5

2 Drawer Sides and Cover Caps (left/right) /Industrial Package			
Silk White(E29)! Grey Matt(E30)!			
NL	Item No.	Set/ctn	
270mm	HE132707X	5	
300mm	HE133007X	5	
350mm	HE133507X	5	
400mm	HE134007X	5	
450mm	HE134507X	5	
500mm	HE135007X	5	
550mm	HE135507X	5	
600mm	HE136007X	5	

3 Front Fixing-brackets (left/right) / Industrial Package			
Pre-zinc Steel(F02)			
	Item No.	Set/ctn	
Screw-on	HE13011X	120	
Press-in	HE13016X	120	

30 Rod for Push-open Synchronization / Industrial Package			
Size:1100mm.Cutting:Internal cabinet width LW-172 for Nominal Side Length: 350mm、400mm、450mm、500mm、550mm、600mm			
Item No.	Set/ctn		
HT0FH02	60		

4 Fixing-brackets			
Zinc plated(B04)			
Item No.	Set/ctn		
HT10082	400		

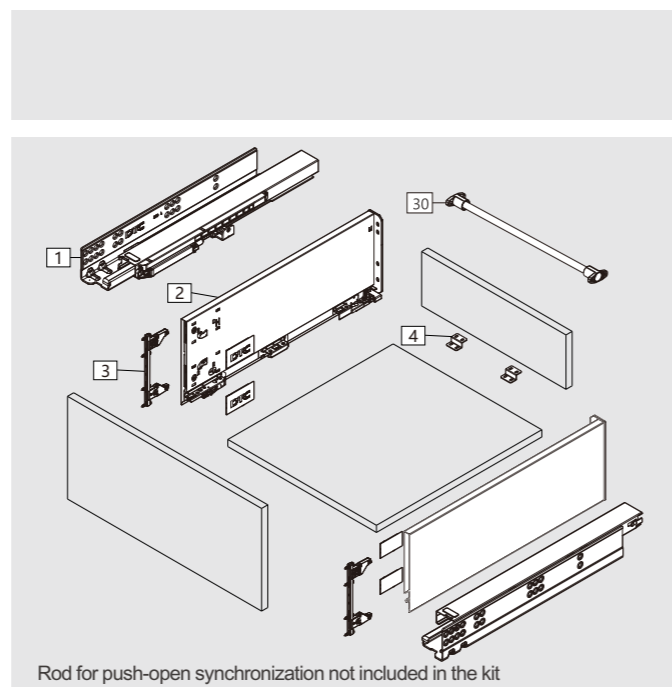

Screw Positions of the Slides(mm)

Cabinet edge	NL
	270
	300
	350
	400
	450
	500
	550
	600

Installation Dimensions(mm)

LW=Internal Cabinet Width

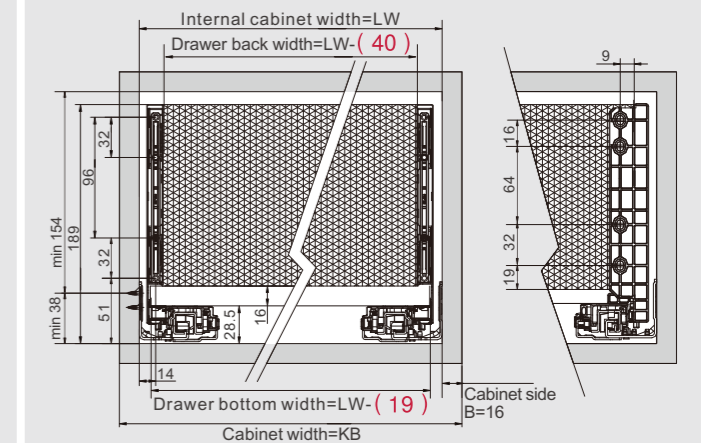

Drawer Front, Back and Bottom Dimensions(mm)

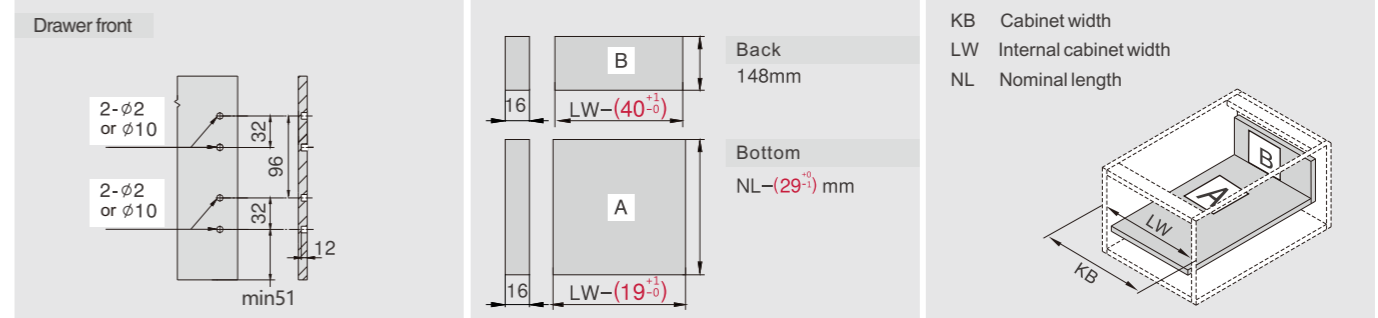

MAGIC-STAR PLUS

HD13 Series Straight-sided Drawer System (High Inner Drawer: C Height)

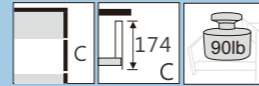

PRODUCT



DESCRIPTION

- Concealed, full extension
- Load capacity: 90lb(40kg)
- Tool free assembly and removal of drawer
- Silent system guarantees smooth run without noise
- 3D adjustment:
Up & down adjustment: ±2mm
left & right adjustment: ±1.2mm
tilt adjustment: +0.5mm, -2.5mm
- Finish: Silk white(E29), Grey matt(E30)

SPACE REQUIREMENT

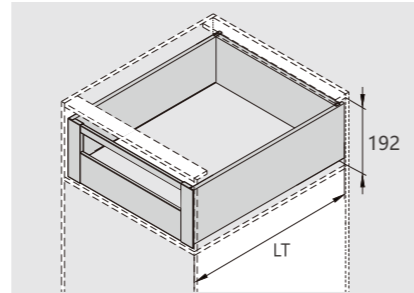

LT=Internal Cabinet Depth
Soft close slides LT=NL+3
Push-open slides LT=NL+13

PLANNING

Installation Dimensions(mm)

NL=Nominal Slide Length Soft close slides LT=NL+3
LT=Internal Cabinet Depth Push-open slides LT=NL+13

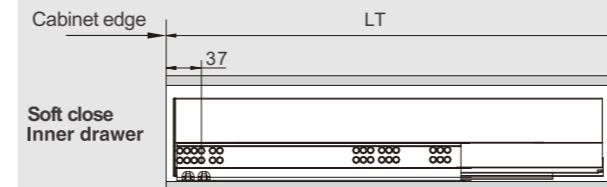

Cabinet Configuration

Cabinet widths/KB(mm)	Push-open drawer Synchronization rod	
300	○	○ recommended
350	○	
400	○	
450	○	
500	○	
600	○	● strongly recommended
800	●	
900	●	
1000	●	
1200	●	

Fixing Hole Position for Push-open Inner Drawer(mm)

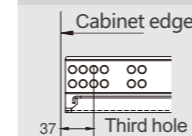

Installation Dimensions(mm)

LW=Internal Cabinet Width

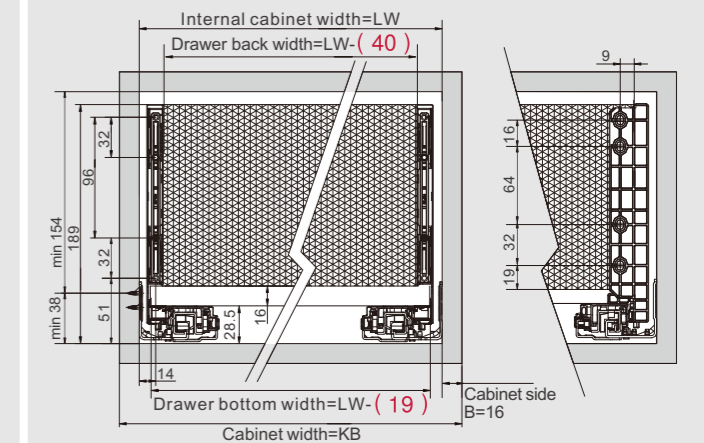

HIGH INNER DRAWER WITH SQUARE CROSS RAIL FOR WOOD DRAWER BACK

Kit Package			
NL	Soft Close item No.	Push-open item No.	Set/ctn
270mm	HD13270Q17X	HD43270Q17X	1
300mm	HD13300Q17X	HD43300Q17X	1
350mm	HD13350Q17X	HD43350Q17X	1
400mm	HD13400Q17X	HD43400Q17X	1
450mm	HD13450Q17X	HD43450Q17X	1
500mm	HD13500Q17X	HD43500Q17X	1
550mm	HD13550Q17X	HD43550Q17X	1
600mm	HD13600Q17X	HD43600Q17X	1

Pre-zinc Steel(F02)			
NL	Soft Close item No.	Push-open item No.	Set/ctn
270mm	HD10270H	HD40270H	5
300mm	HD10300H	HD40300H	5
350mm	HD10350H	HD40350H	5
400mm	HD10400H	HD40400H	5
450mm	HD10450H	HD40450H	5
500mm	HD10500H	HD40500H	5
550mm	HD10550H	HD40550H	5
600mm	HD10600H	HD40600H	5

Drawer Sides and Cover Caps (left/right) /Industrial Package		
NL	Item No.	Set/ctn
270mm	HE132707X	5
300mm	HE133007X	5
350mm	HE133507X	5
400mm	HE134007X	5
450mm	HE134507X	5
500mm	HE135007X	5
550mm	HE135507X	5
600mm	HE136007X	5

Front Fixing-brackets (left/right) / Industrial Package	
Item No.	Set/ctn
White(H03)! Dark Grey(H11)	60
Item No. HD13014X	

Square Cross Rail / Industrial Package	
Item No.	Set/ctn
Silk White(E29)! Grey Matt(E30)	60
Size:1100mm.Cutting: Item No. HT10071	
Internal cabinet width LW-72	

Front Section / Industrial Package	
Item No.	Set/ctn
Size:1100mm.Cutting:Internal cabinet width LW-97	20
Silk White(E29)! Grey Matt(E30)	
Item No. HT10022	

Rod for Push-open Synchronization / Industrial Package	
Item No.	Set/ctn
Size:1100mm.Cutting:Internal cabinet width LW-172 for Nominal Side Length: 350mm、400mm、450mm、500mm、550mm、600mm	60
Item No. HT0FH02	

Fixing-brackets	
Item No.	Pcs/ctn
Zinc plated(B04)	400
Item No. HT10082	

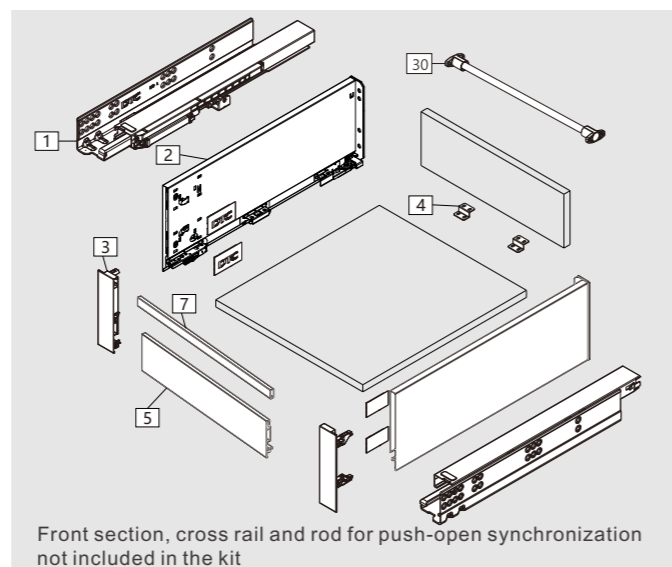

Screw Positions of the Slides(mm)

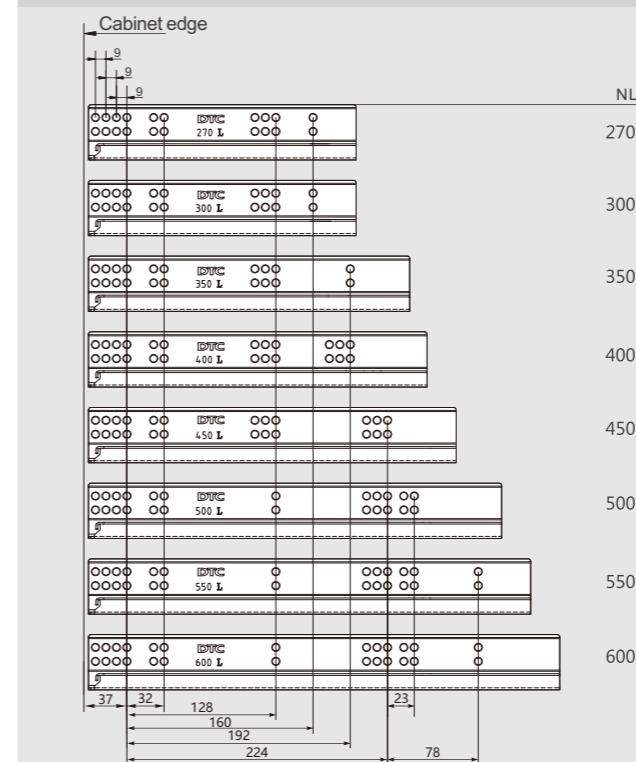

Front Section, Back and Bottom Dimensions(mm)

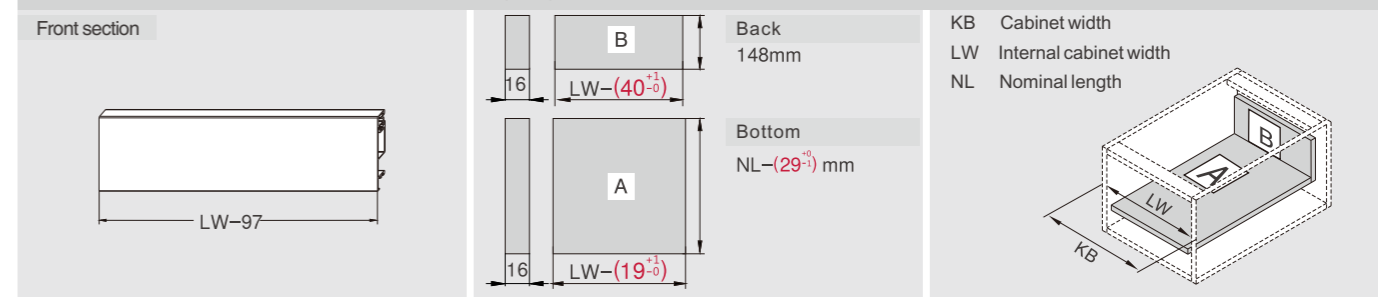

MAGIC-STAR PLUS

HD14 Series Straight-sided Drawer System (Super High Drawer: F Height)

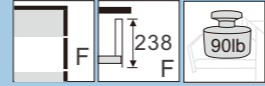

PRODUCT



DESCRIPTION

- Concealed, full extension
- Load capacity: 90lb(40kg)
- Tool free assembly and removal of drawer
- Silent system guarantees smooth run without noise
- 3D adjustment:
Up & down adjustment: ±2mm
left & right adjustment: ±1.2mm
tilt adjustment: +0.5mm, -2.5mm
- Finish: Silk white(E29), Grey matt(E30)

SPACE REQUIREMENT

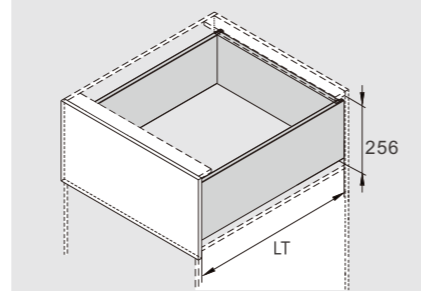

LT=Internal Cabinet Depth
LT=NL+3

PLANNING

Installation Dimensions(mm)

NL=Nominal Slide Length
LT=Internal Cabinet Depth
LT=NL+3

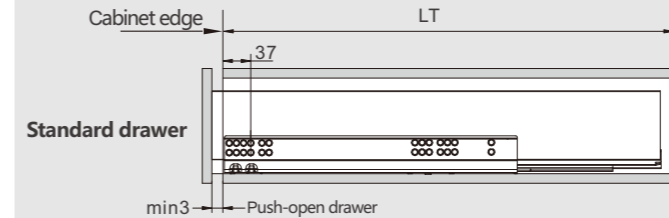

Cabinet Configuration

Cabinet widths/KB(mm)	Push-open drawer Synchronization rod	
300	○	○ recommended
350	○	
400	○	
450	○	
500	○	
600	○	● strongly recommended
800	●	
900	●	
1000	●	
1200	●	

SUPER HIGH DRAWER FOR WOOD DRAWER BACK

Kit Package			
Silk White(E29)! Grey Matt(E30)!			
NL	Soft Close item No.	Push-open item No.	Set/ctn
270mm	HD14270A17X	HD44270A17X	1
300mm	HD14300A17X	HD44300A17X	1
350mm	HD14350A17X	HD44350A17X	1
400mm	HD14400A17X	HD44400A17X	1
450mm	HD14450A17X	HD44450A17X	1
500mm	HD14500A17X	HD44500A17X	1
550mm	HD14550A17X	HD44550A17X	1
600mm	HD14600A17X	HD44600A17X	1

1 Slides (left/right) /Industrial Package			
Pre-zinc Steel(F02)			
NL	Soft Close item No.	Push-open item No.	Set/ctn
270mm	HD10270H	HD40270H	5
300mm	HD10300H	HD40300H	5
350mm	HD10350H	HD40350H	5
400mm	HD10400H	HD40400H	5
450mm	HD10450H	HD40450H	5
500mm	HD10500H	HD40500H	5
550mm	HD10550H	HD40550H	5
600mm	HD10600H	HD40600H	5

2 Drawer Sides and Cover Caps (left/right) /Industrial Package			
Silk White(E29)! Grey Matt(E30)!			
NL	Item No.	Set/ctn	
270mm	HE142707X	5	
300mm	HE143007X	5	
350mm	HE143507X	5	
400mm	HE144007X	5	
450mm	HE144507X	5	
500mm	HE145007X	5	
550mm	HE145507X	5	
600mm	HE146007X	5	

3 Front Fixing-brackets (left/right) / Industrial Package			
Pre-zinc Steel(F02)			
	Item No.	Set/ctn	
Screw-on	HE13011X	120	
Press-in	HE13016X	120	

4 Fixing-brackets			
Zinc plated(B04)			
	Item No.	Set/ctn	
	HT10082	400	

30 Rod for Push-open Synchronization / Industrial Package			
Size:1100mm.Cutting:Internal cabinet width LW-172 for Nominal Side Length: 350mm、400mm、450mm、500mm、550mm、600mm			
	Item No.	Set/ctn	
	HT0FH02	60	

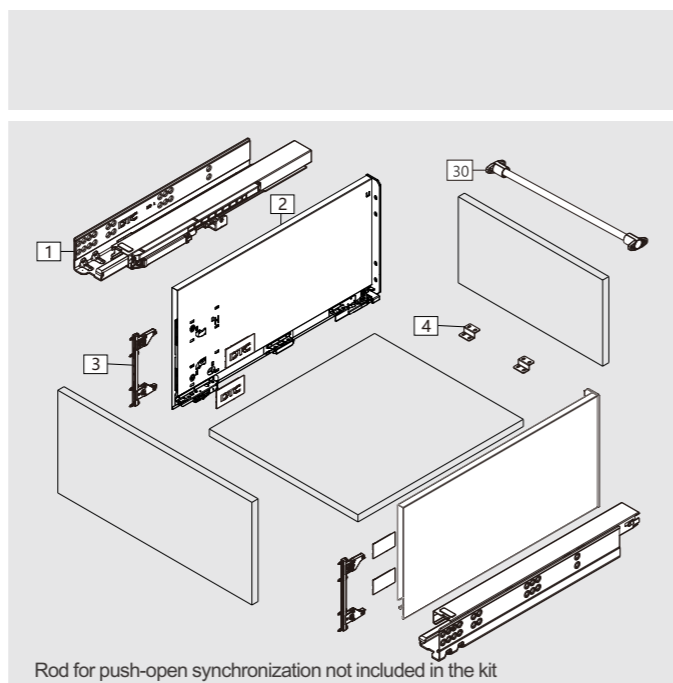

Screw Positions of the Slides(mm)

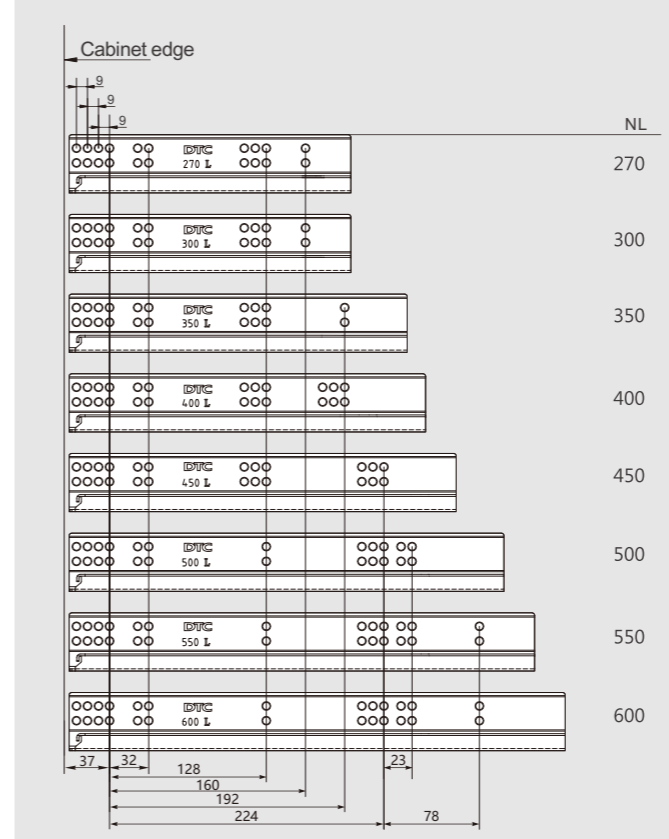

Installation Dimensions(mm)

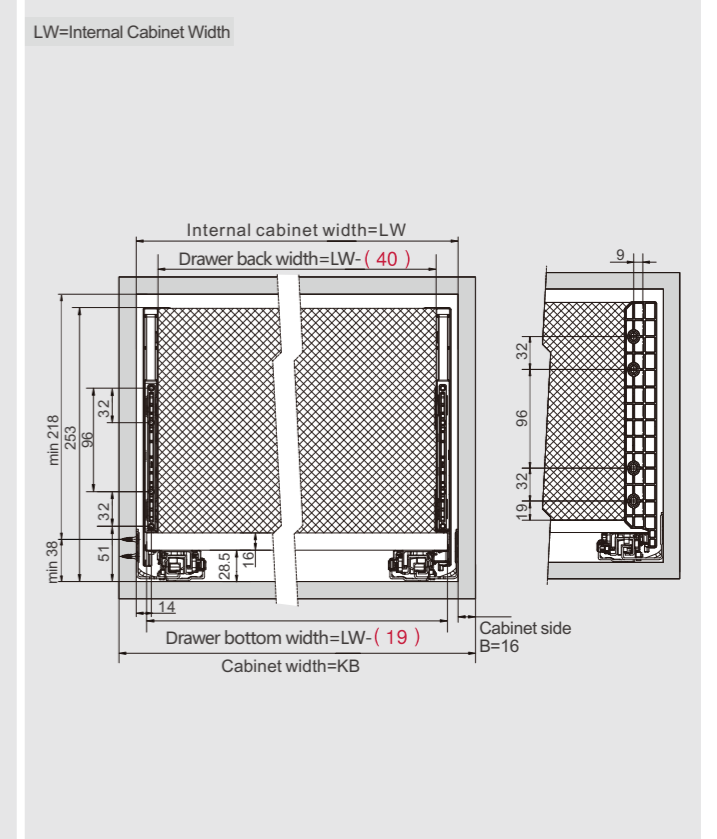

Drawer Front, Back and Bottom Dimensions(mm)

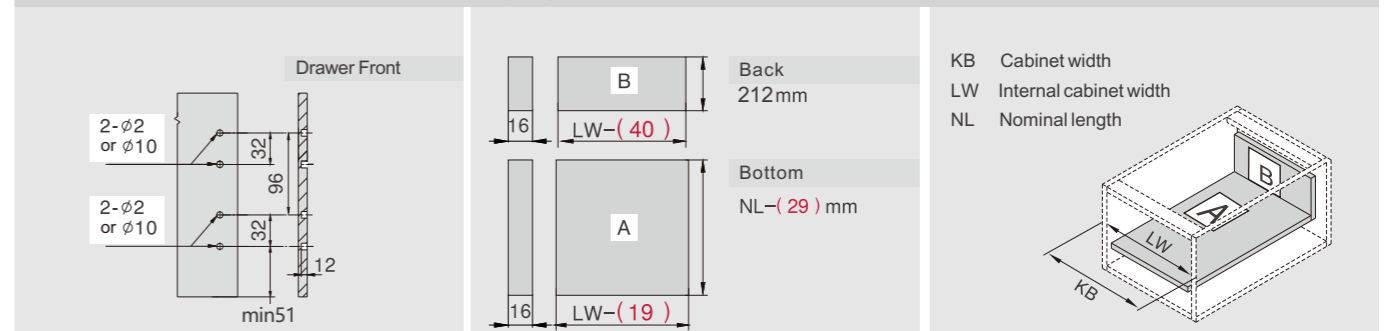

ASSEMBLY AND ADJUSTMENT

Assembly and Adjustment(for MAGIC-STAR PLUS)

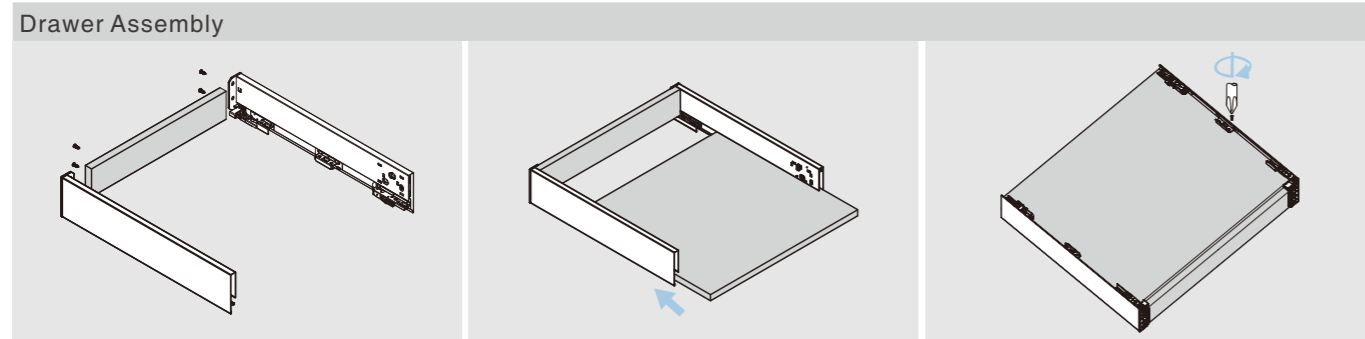

Back assembly

Bottom assembly

Fix screws

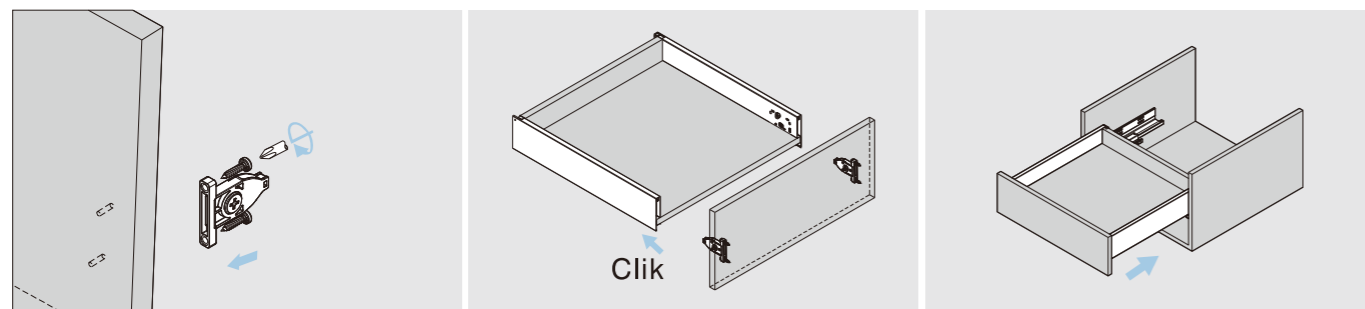

Front assembly

Click

Slide into the cabinet

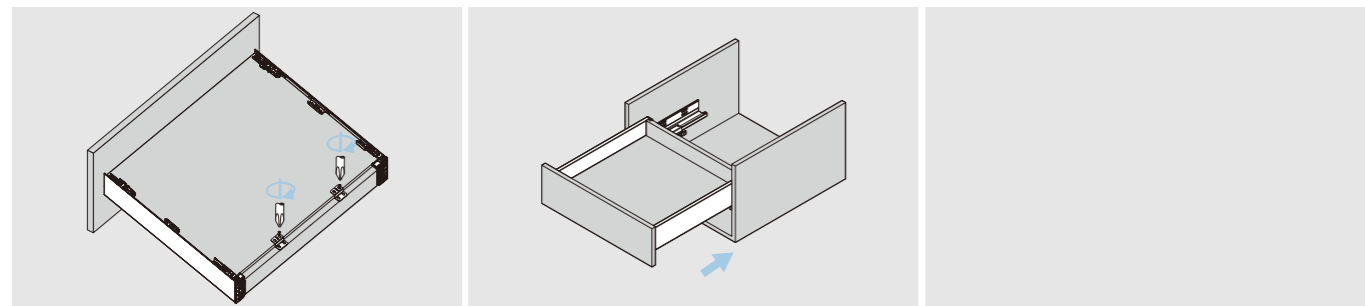

Fixing-brackets assembly

Slide into the cabinet

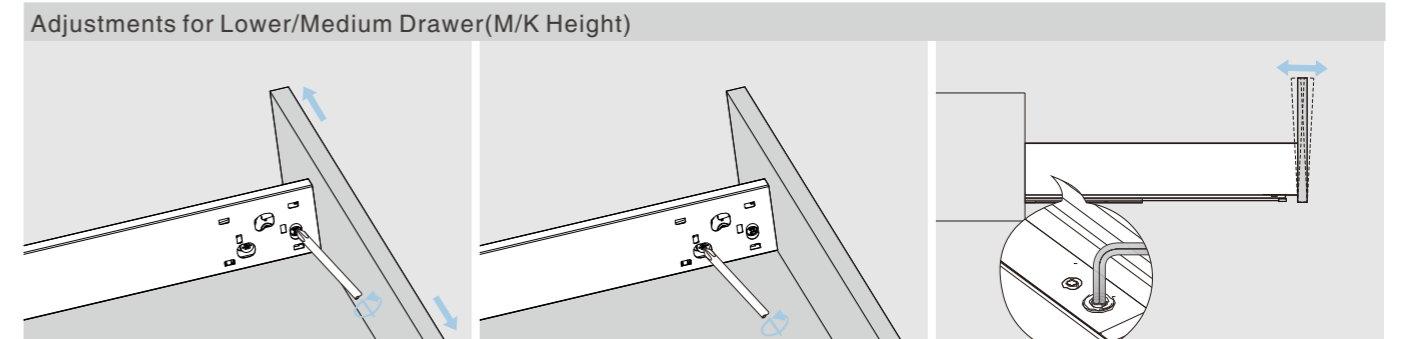

Left&right adjustment

Up&down adjustment

Tilt adjustment (by M3 Allen key)

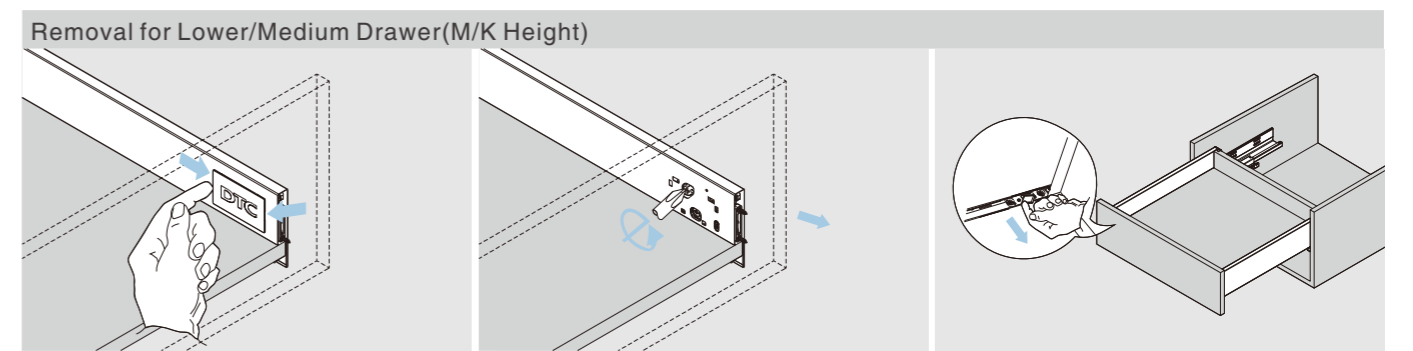

Tip up the cover and pull out

Turn screw driver to release the drawer front

Press the locking device under drawer bottom and pull out the drawer

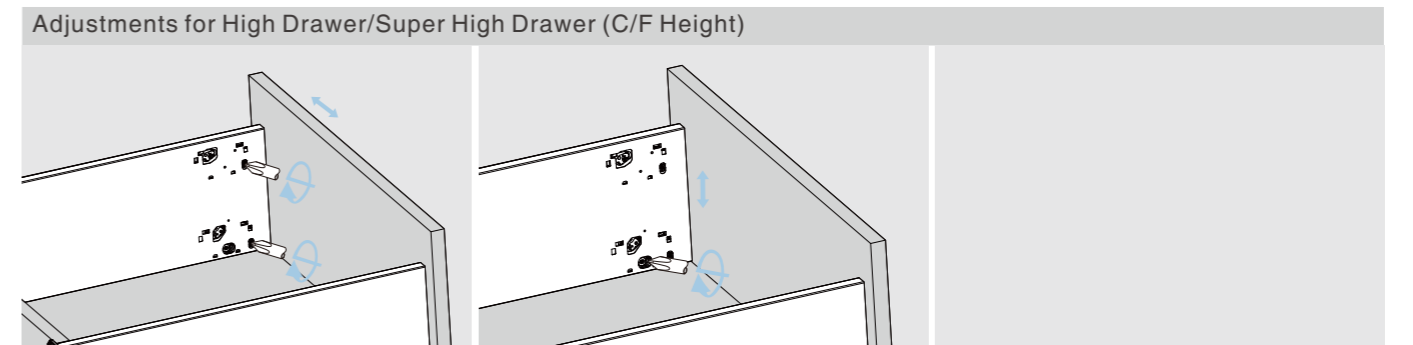

Left&right adjustment

Up&down adjustment

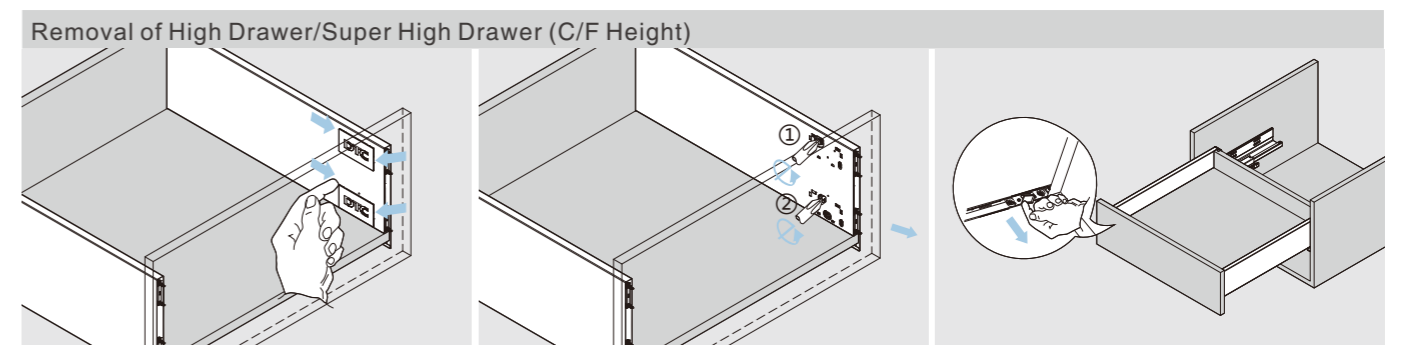

Tip up the cover and pull out

Turn screw driver to release the drawer front

Press the locking device under drawer bottom and pull out the drawer

METAL DRAWER BACKS

Metal Drawer Backs (for MAGIC-STAR PLUS)



ORDER INFORMATION

Low Drawer: M Height		
Silk White(E29)! Grey Matt(E30)!		
Cabinet width(mm)	Item No.	Pcs/ctn
300	HE1103F300	20
325	HE1103F325	20
350	HE1103F350	20
375	HE1103F375	20
400	HE1103F400	20
450	HE1103F450	20
500	HE1103F500	20
600	HE1103F600	20
700	HE1103F700	20
800	HE1103F800	20
900	HE1103F900	20
1000	HE1103F1000	20
1200	HE1103F1200	20

Medium Drawer: K Height		
Silk White(E29)! Grey Matt(E30)!		
Cabinet width(mm)	Item No.	Pcs/ctn
300	HE1203F300	20
325	HE1203F325	20
350	HE1203F350	20
375	HE1203F375	20
400	HE1203F400	20
450	HE1203F450	20
500	HE1203F500	20
600	HE1203F600	20
700	HE1203F700	20
800	HE1203F800	20
900	HE1203F900	20
1000	HE1203F1000	20
1200	HE1203F1200	20

High Drawer: C Height		
Silk White(E29)! Grey Matt(E30)!		
Cabinet width(mm)	Item No.	Pcs/ctn
300	HE1303F300	20
325	HE1303F325	20
350	HE1303F350	20
375	HE1303F375	20
400	HE1303F400	20
450	HE1303F450	20
500	HE1303F500	20
600	HE1303F600	20
700	HE1303F700	20
800	HE1303F800	20
900	HE1303F900	20
1000	HE1303F1000	20
1200	HE1303F1200	20

Super High Drawer: C Height		
Silk White(E29)! Grey Matt(E30)!		
Cabinet width(mm)	Item No.	Pcs/ctn
300	HE1403F300	20
325	HE1403F325	20
350	HE1403F350	20
375	HE1403F375	20
400	HE1403F400	20
450	HE1403F450	20
500	HE1403F500	20
600	HE1403F600	20
700	HE1403F700	20
800	HE1403F800	20
900	HE1403F900	20
1000	HE1403F1000	20
1200	HE1403F1200	20

Cutting Dimensions for 16mm Chipboard Bottom

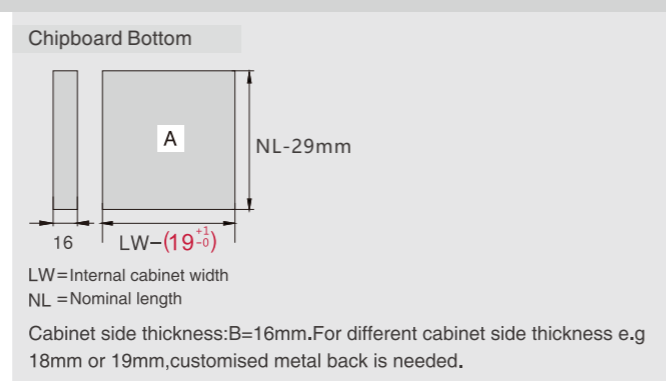
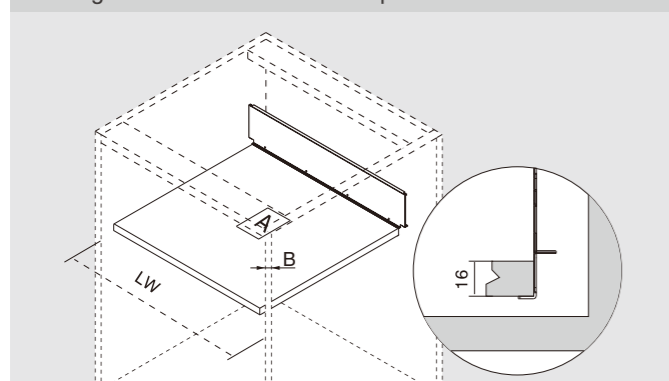

DIVIDING ACCESSORIES

Dividing Accessories (for MAGIC-STAR PLUS)

ORDER INFORMATION

Applicable with Metal Drawer Side	
3	Divider/Industrial Package White(H03)! Dark Grey(H11) Item No. HT10074 Set/ctn 60
4	Square Cross Rail Connector/Industrial Package White(H03)! Dark Grey(H11) Item No. HT10072 Set/ctn 120
5	Square Cross Rail/Industrial Package Silk White(E29)! Grey Matt(E30) Item No. HT10071 Set/ctn 20 (Size:1100mm Cutting:Internal Cabinet width LW-72)Applicable with MAGIC-PRO, MAGIC-STAR

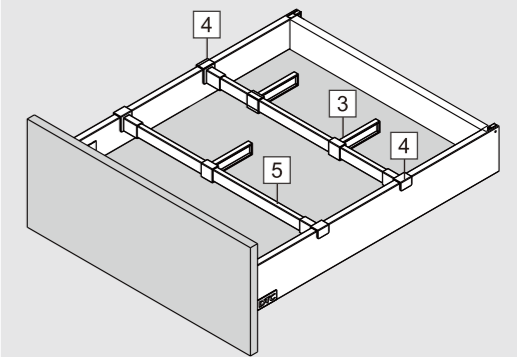

Applicable with Glass-box Drawer Side	
3	Divider/Industrial Package White(H03)! Dark Grey(H11) Item No. HT10074 Set/ctn 60
6	Square Cross Rail Connector/Industrial Package White(H03)! Dark Grey(H11) Item No. HT10073 Set/ctn 120
5	Square Cross Rail/Industrial Package Silk White(E29)! Grey Matt(E30) Item No. HT10071 Set/ctn 20 (Size:1100mm Cutting:Internal Cabinet width LW-72)Applicable with MAGIC-PRO, MAGIC-STAR (Size:1100mm Cutting:Internal Cabinet width LW-74)Applicable with DRAGON-PRO

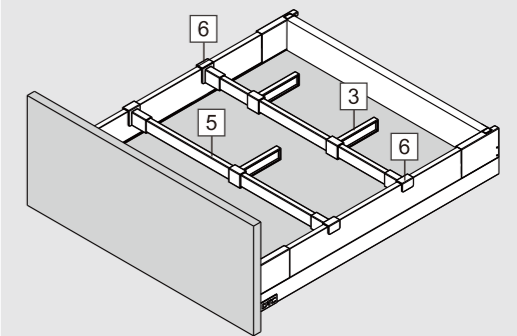

Applicable with Metal Drawer Side	
3	Divider/Industrial Package White(H03)! Dark Grey(H11) Item No. M01076 Set/ctn 60
4	Square Cross Rail Connector/Industrial Package White(H03)! Dark Grey(H11) Item No. HB01075 Set/ctn 60
5	Cross Divider/Industrial Package Silk White(E29)! Grey Matt(E30) Item No. M01023 Set/ctn 20 (Size:1100mm Cutting:Internal Cabinet width LW-72)Applicable with MAGIC-PRO, MAGIC-STAR (Size:1100mm Cutting:Internal Cabinet width LW-74)Applicable with DRAGON-PRO

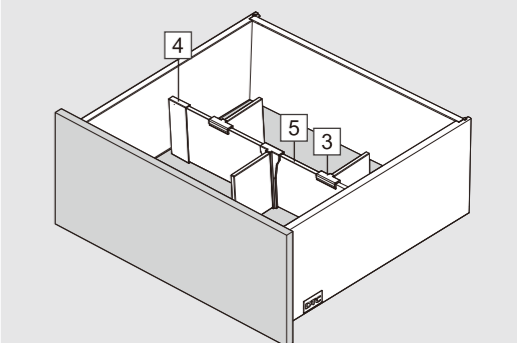

Applicable with Metal Drawer Side(Wood Back)	
3	Divider/Industrial Package White(H03)! Dark Grey(H11) Item No. M01076 Set/ctn 60
4	Square Cross Rail Connector/Industrial Package White(H03)! Dark Grey(H11) Item No. HB01075 Set/ctn 60
5	Cross Divider/Industrial Package Silk White(E29)! Grey Matt(E30) Item No. M01023 Set/ctn 20 (Size:1100mm Cutting:Internal Cabinet width NL-92)Applicable with MAGIC-PRO, MAGIC-STAR (Size:1100mm Cutting:Internal Cabinet width NL-87)Applicable with DRAGON-PRO

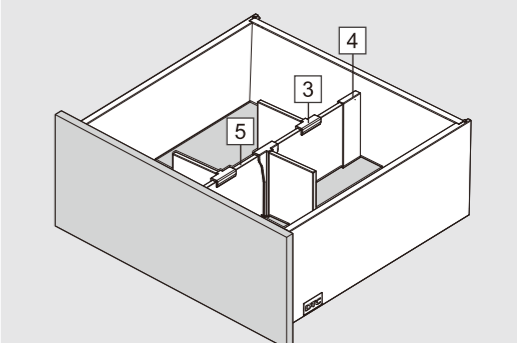

DRAWER SYSTEMS